

IGNITION :

Ignition unit : CDI (specific 4 poles)

Spark plug : KWAS 850 or NGK BR7HS according to spark plug cap.

Electrode gap : 0,5 to 0,6 mm

Ignition advance : 17°

Ignition coil : TEC MP11 or TIICX7A

Primary winding resistance : $0,26 \Omega \pm 20 \%$

Secondary winding resistance : $3 \text{ k}\Omega \pm 20 \%$

Spark plug cap resistance : $5 \text{ k}\Omega \pm 10 \%$

ELECTRICAL EQUIPMENT :

Current generator (type and power) : 4 poles

Make : PEUGEOT

Stator resistance : Red/black wire : $800 \Omega \pm 20 \%$

Yellow wire : $1 \Omega \pm 20 \%$

Lighting voltage : alternating current regulation at : $13,1 \pm 0,5 \text{ V}$

STARTER :

With foot starter

LIGHTING AND FUSES :

	Quantity	Power
Headlamp (code light) :	1	12V - 15W
Red stop lamp :	2	12V - 4W 12V - 10W
Indicator lamps :	*	*
Number plate lightning :	*	*
Dash board lighting :	*	*
Instrument panel indicator lamps :	*	*
Main fuse :	*	*
Signalling fuse :	*	*
"Side light" bulb :	*	*

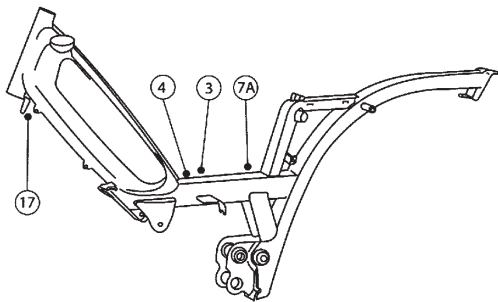
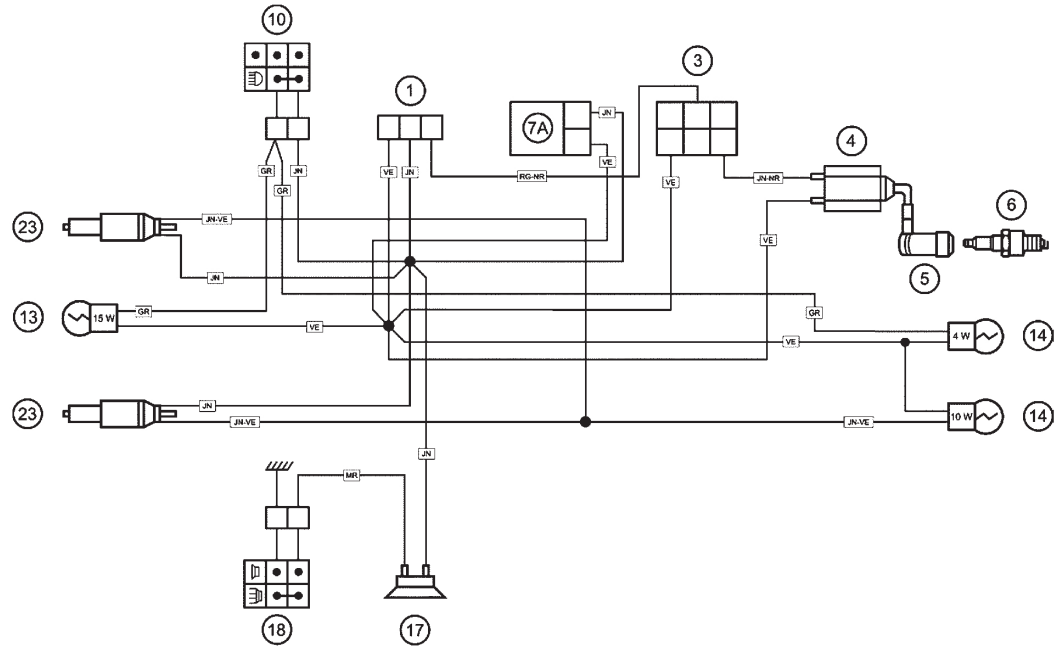

- A Instrument panel lightning
- B Main beam control
- C Oil level warning light
- D Indicator control light
- E Fuel gauge
- F LED "Anti theft device"
- G Temperature gauge
- H Warning light "reserve"
- J Oil pressure warning light

- 1) Generator
 - a : Ignition coil (inner)
 - b : Pickup
 - c : Alternating current
 - d : Battery charge current
- 2) Ignition switch
- 3) CDI unit
- 4) Ignition coil (High voltage)
- 5) Spark plug socket (resistive) 5 k Ω
- 6) Spark plug (resistive) 5 k Ω

- 7) Regulator, rectifier
 - (A) : Regulator AC
 - (B) : (Regulator) rectifier DC
- 8) Automatic choke
- 9) Resistor (in line with choke) 6,7 Ω - 5W
- 10) Light switch
- 11) Resistor (parallel to lightning) 5,9 Ω - 30W
- 12) Dip switch (main/low headlight)
- 13) Headlight
- 14) Stop /tail light
- 15) Battery
- 16) Fuse
- 17) Horn
- 18) Horn switch
- 19) Indicator relay
- 20) Indicator switch
- 21) Indicator bulb
- 22) Fuel gauge pickup

- 23) Stop light switch
- 24) Starter relay
- 25) Starter switch
- 26) Starter motor
- 27) Current limiter
- 28) Oil level switch
- 29) Temperature sensor
- 30) Immobilizer
- 31) Antenna for anti-theft device
- 32) "Side light" bulb
- 33) Number plate light
- 34) Lateral stand switch
- 35) Emergency switch (ignition)
- 36) "Neutral" switch (gearbox)
- 37) Oil pressure switch
- 38) Cooling fan
- 39) Thermo-switch cooling fan
- 40) Electrical carburettor heating
- 41) Power supply unit
- 42) Switch "Reserve"

- BA : White
- BA-BE : White/Blue
- BA-NR : White/Black
- BC : Light blue
- BE : Blue
- GR : Grey
- JN : Yellow
- JN-BA : Yellow/White
- JN-BE : Yellow/Blue
- JN-NR : Yellow/Black
- JN-VE : Yellow/Green
- MR : Brown
- NR : Black
- OR : Orange
- RG : Red
- RG-NR : Red/Black
- RS : Pink
- VE : Green
- VE-NR : Green/Black
- VI : Purple